

Part Numbers	Specifications	Applications	Features	Options
<b>6403295</b> PUSHER / PULLER	<b>DIAMETER 14" (350 mm)</b> <b>LOW PROFILE</b> <b>12V 160W</b>	HVAC Systems	Waterproof, IP68 (LL) Long Life Reversible Airflow High Efficiency	Mounting brackets EMC (Certified) Thermal Protector (ELL) Extreme Long Life

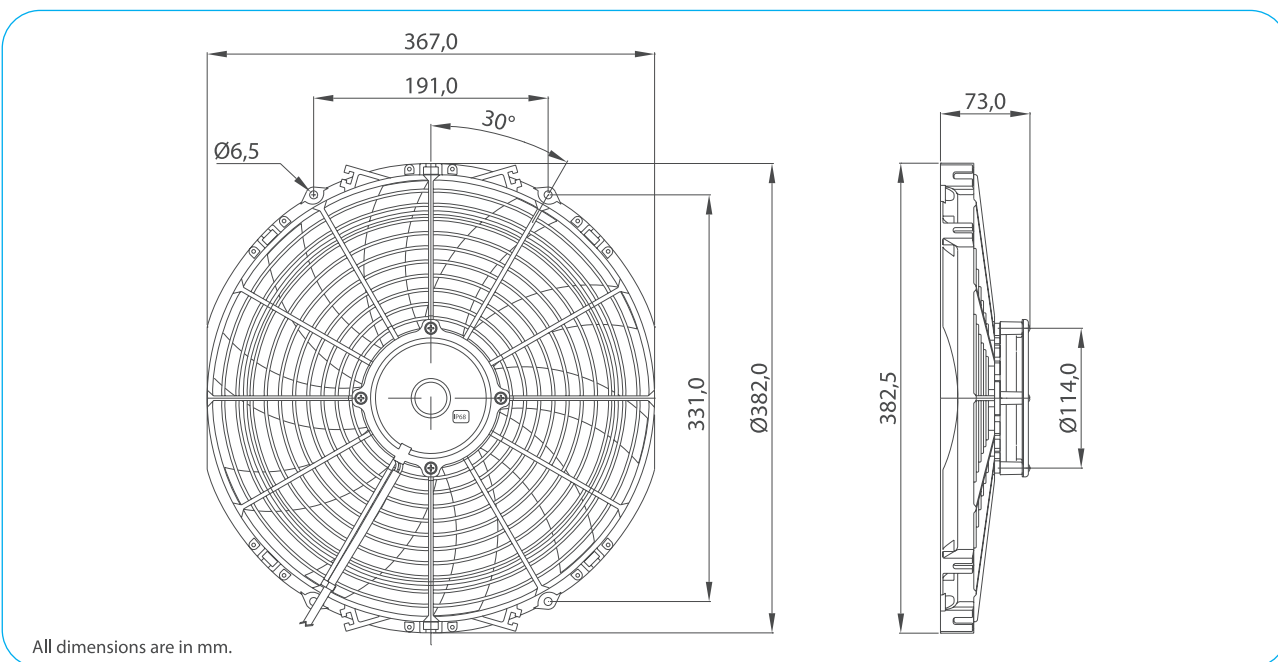

Test Voltage	V	13,0
Nominal Current	A	7,0
Nominal Speed	rpm	2.250
Max. St. Pressure	mmH <sub>2</sub> O	15,0
Max. Airflow	m <sup>3</sup> /h	2.400
Weight	kg	2,0



TEST VOLTAGE = 13,0 VDC	Static Pressure	Air Flow Rate	Current
	mm H <sub>2</sub> O	m <sup>3</sup> /h	A
	0,0	2398,9	7,0
	2,5	2167,3	7,5
	5,0	1927,5	8,1
	7,5	1596,4	8,3
	10,0	1062,9	7,6
	12,5	495,2	7,3
	15,0	0,0	7,8

Static Pressure: 1 mm H<sub>2</sub>O = 0,04in H<sub>2</sub>O = 9,8 Pa  
Air Flow Rate: 1 m<sup>3</sup>/h = 0,59 cfm

