

Part Numbers	Specifications	Applications	Features	Options
6401264 PULLER / STR. BLADE	DIAMETER 12" (305 mm)	HVAC Systems	Waterproof, IP68 (LL) Long Life High Efficiency	Mounting brackets EMC (Certified) Thermal Protector (ELL) Extreme Long Life
6401266 PUSHER / STR. BLADE	HIGH PROFILE 24V 225W			

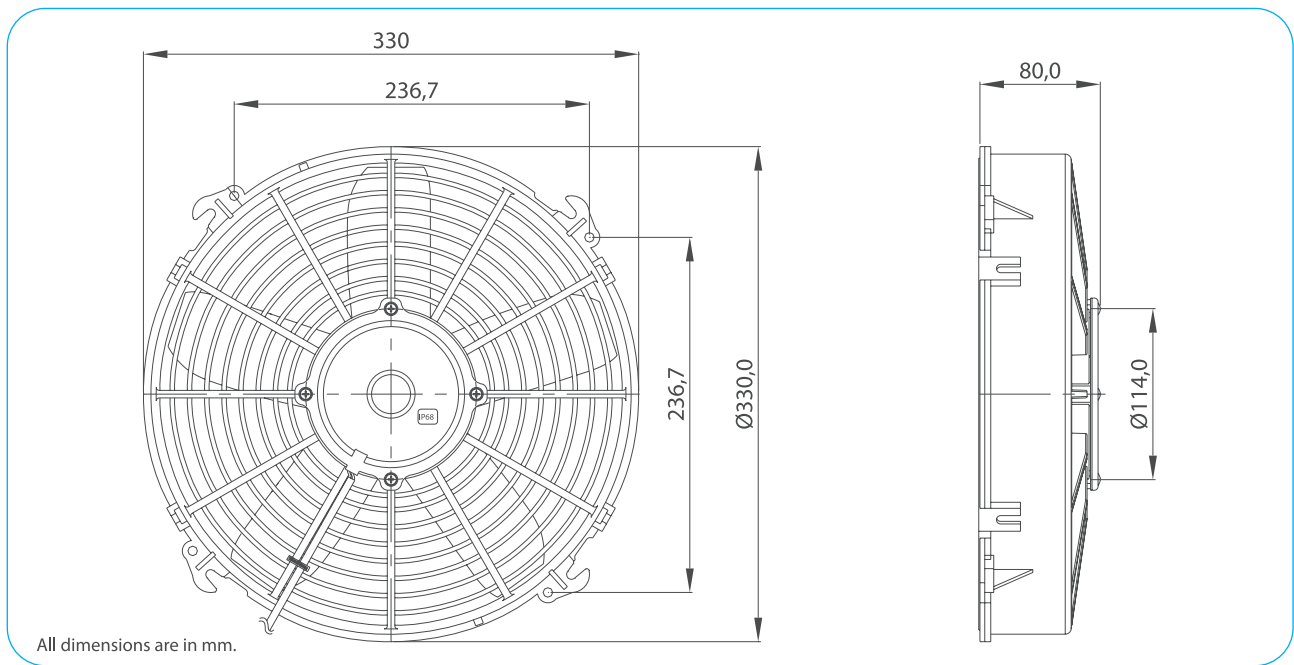

Test Voltage	V	26,0
Nominal Current	A	8,6
Nominal Speed	rpm	3.000
Max. St. Pressure	mmH ₂ O	41,5
Max. Airflow	m ³ /h	2.730
Weight	kg	2,4



TEST VOLTAGE = 26,0 VDC	Static Pressure	Air Flow Rate	Current
	mm H ₂ O	m ³ /h	A
	0,0	2722,8	8,6
	2,5	2638,2	8,8
	5,0	2526,1	9,0
	7,5	2358,8	9,1
	10,0	2119,1	9,1
	15,0	1565,9	9,2
	20,0	1160,4	9,7
	25,0	869,6	10,1
	30,0	593,3	10,4
	41,4	0,0	12,6

Static Pressure: 1 mm H₂O = 0,04in H₂O = 9,8 Pa
Air Flow Rate: 1 m³/h = 0,59 cfm

