

Part Numbers	Specifications	Applications	Features	Options
6402259 PULLER / STR. BLADE	DIAMETER 14" (350 mm)	HVAC Systems	Waterproof, IP68 (LL) Long Life High Efficiency	Mounting brackets EMC (Certified) Thermal Protector (ELL) Extreme Long Life
6401255 PUSHER / STR. BLADE	LOW PROFILE 24V 160W			

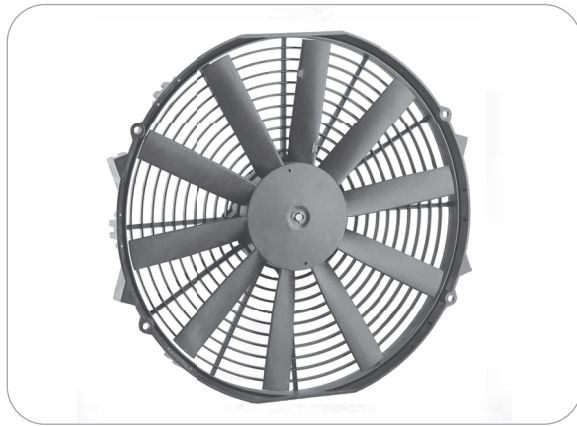

Test Voltage	V	26,0
Nominal Current	A	4,5
Nominal Speed	rpm	2.850
Max. St. Pressure	mmH ₂ O	25,0
Max. Airflow	m ³ /h	2.260
Weight	kg	1,8

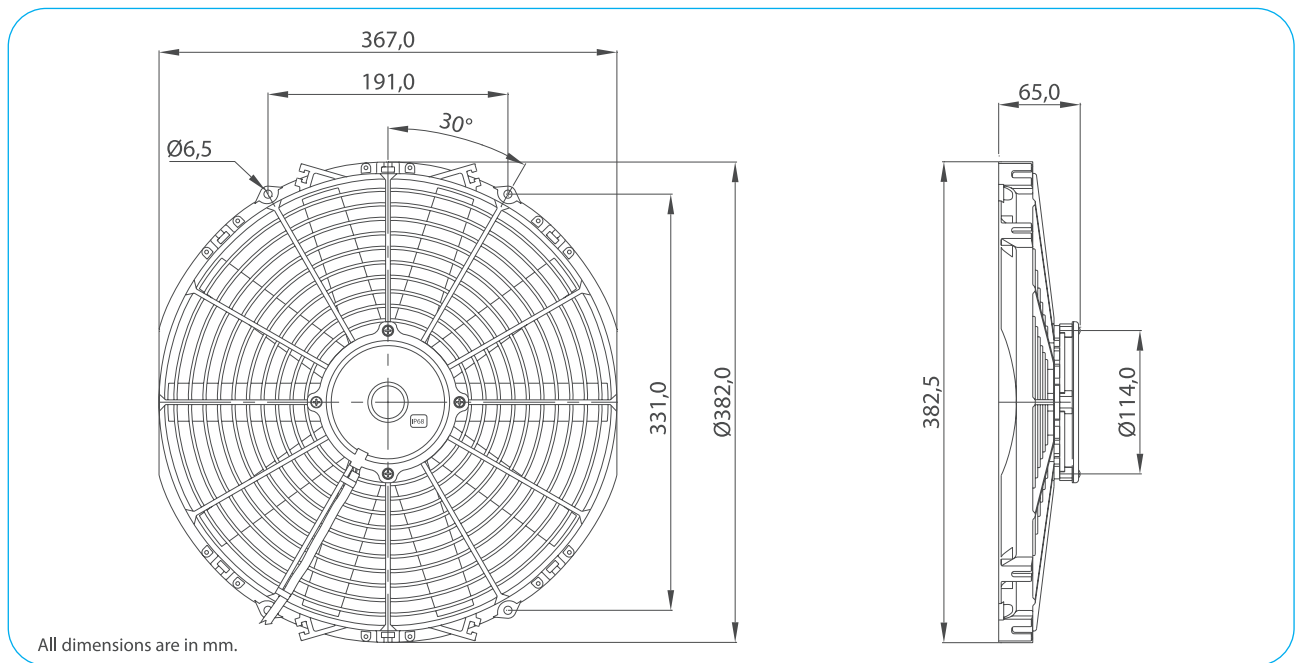

TEST VOLTAGE = 26,0 VDC	Static Pressure	Air Flow Rate	Current
	mm H ₂ O	m ³ /h	A
	0,0	2266,1	4,6
	2,5	2121,6	4,8
	5,0	1969,8	5,1
	7,5	1799,3	5,3
	10,0	1580,3	5,5
	12,5	1292,7	5,4
	15,0	990,9	5,3
	17,5	737,2	5,3
20,0	507,9	5,3	
24,9	0,0	5,1	

Static Pressure: 1 mm H₂O = 0,04in H₂O = 9,8 Pa
Air Flow Rate: 1 m³/h = 0,59 cfm

