

Part Numbers	Specifications	Applications	Features	Options
6402261 PULLER / STR. BLADE	DIAMETER 14" (350 mm)	HVAC Systems	Waterproof, IP68 (LL) Long Life High Efficiency	Mounting brackets EMC (Certified) Thermal Protector (ELL) Extreme Long Life
6401260 PUSHER / STR. BLADE	LOW PROFILE 24V 225W			

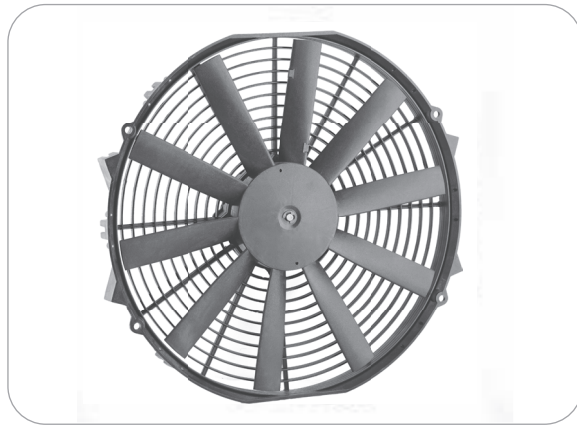

Test Voltage	V	26,0
Nominal Current	A	6,8
Nominal Speed	rpm	3.230
Max. St. Pressure	mmH ₂ O	32,0
Max. Airflow	m ³ /h	2.680
Weight	kg	2,2

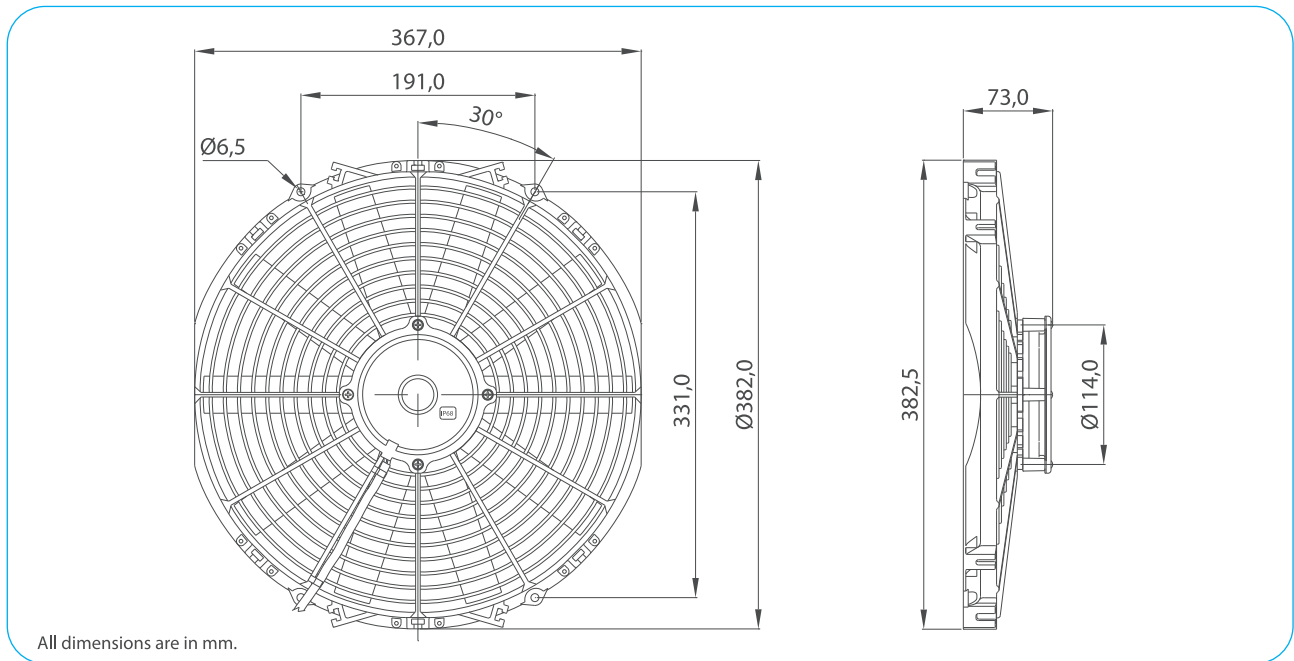

TEST VOLTAGE = 26,0 VDC	Static Pressure	Air Flow Rate	Current
	mm H ₂ O	m ³ /h	A
	0,0	2677,9	6,8
	2,5	2556,6	6,9
	5,0	2427,7	7,1
	7,5	2279,9	7,3
	10,0	2111,0	7,5
	15,0	1660,6	7,6
	20,0	1122,9	7,3
	25,0	643,5	7,1
30,0	199,5	6,8	
32,3	0,0	6,7	

Static Pressure: 1 mm H₂O = 0,04in H₂O = 9,8 Pa
Air Flow Rate: 1 m³/h = 0,59 cfm

