

Part Numbers	Specifications	Applications	Features	Options
6402266 PULLER / STR. BLADE	DIAMETER 16" (385 mm)	HVAC Systems	Waterproof, IP68 (LL) Long Life High Efficiency	Mounting brackets EMC (Certified) Thermal Protector (ELL) Extreme Long Life
6401261 PUSHER / STR. BLADE	LOW PROFILE 12V 225W			

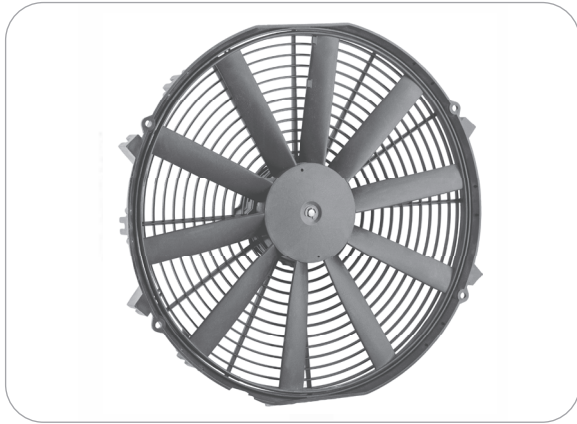

Test Voltage	V	13,0
Nominal Current	A	14,5
Nominal Speed	rpm	3.100
Max. St. Pressure	mmH ₂ O	28,0
Max. Airflow	m ³ /h	2.830
Weight	kg	2,3

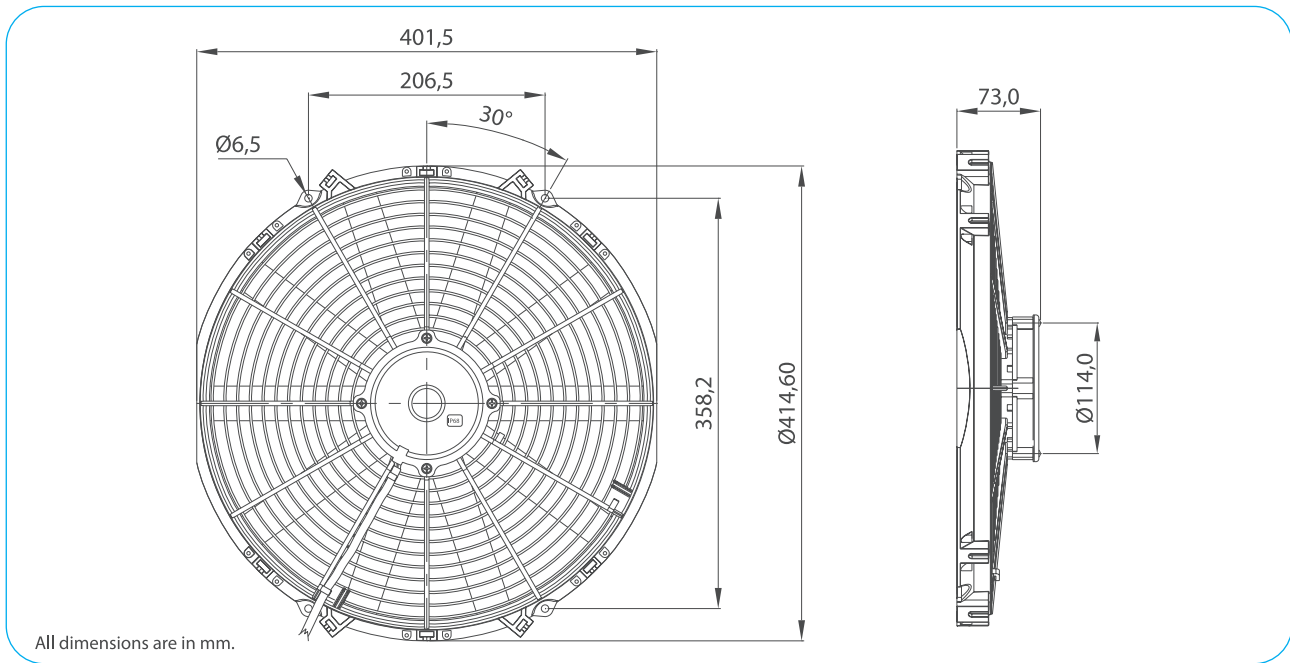

TEST VOLTAGE = 13,0 VDC	Static Pressure	Air Flow Rate	Current
	mm H ₂ O	m ³ /h	A
	0,0	2831,4	14,2
	2,5	2663,1	14,7
	5,0	2492,1	15,1
	7,5	2311,4	15,4
	10,0	2094,4	15,6
	12,5	1818,2	15,5
	15,0	1507,4	15,3
	20,0	904,5	14,9
25,0	349,0	14,4	
28,2	0,0	13,9	

Static Pressure: 1 mm H₂O = 0,04in H₂O = 9,8 Pa
Air Flow Rate: 1 m³/h = 0,59 cfm

