

Part Numbers	Specifications	Applications	Features	Options
<b>6403317</b> PUSHER / PULLER	<b>DIAMETER 12" (305 mm)</b> <b>LOW PROFILE</b> <b>12V 160W</b>	HVAC Systems	Waterproof, IP68 (LL) Long Life Reversible Airflow High Efficiency	Mounting brackets EMC (Certified) Thermal Protector (ELL) Extreme Long Life

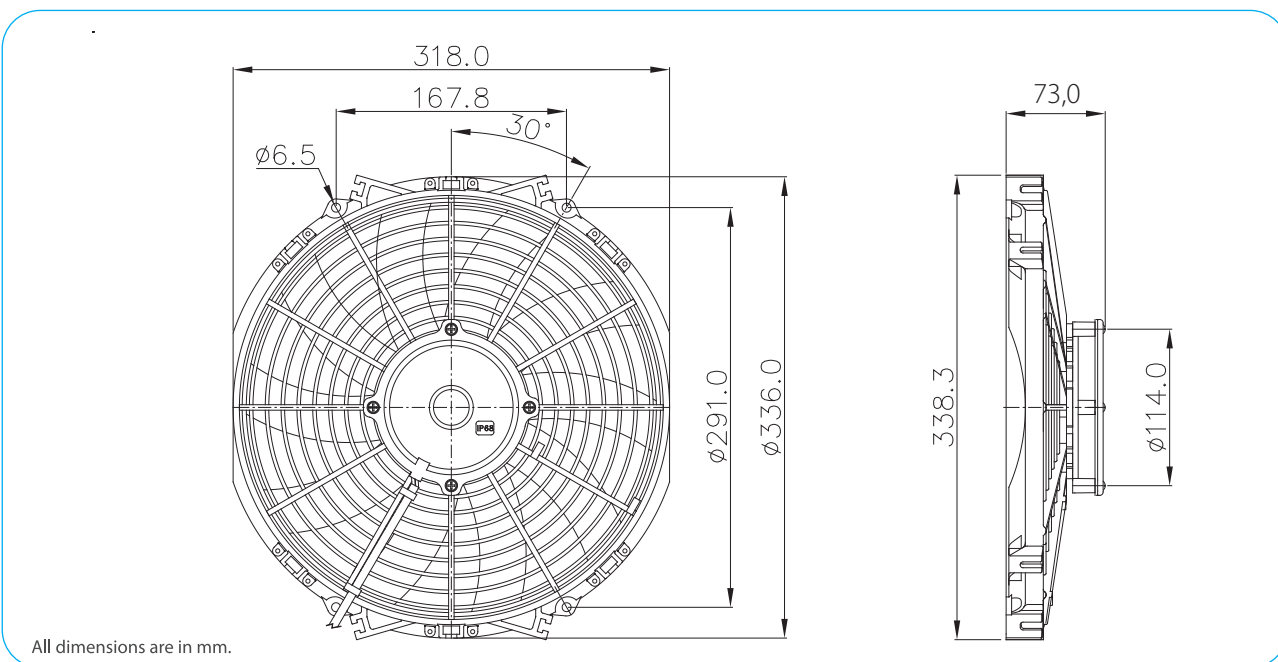

Test Voltage	V	13,0
Nominal Current	A	11,0
Nominal Speed	rpm	2.900
Max. St. Pressure	mmH <sub>2</sub> O	21,0
Max. Airflow	m <sup>3</sup> /h	2.060
Weight	kg	1,9



TEST VOLTAGE = 13,0 VDC	Static Pressure	Air Flow Rate	Current
	mm H <sub>2</sub> O	m <sup>3</sup> /h	A
	0,0	2058,6	10,6
	2,5	1931,6	11,0
	5,0	1772,8	11,4
	7,5	1522,5	11,5
	10,0	1140,9	11,1
	12,5	811,2	10,8
	15,0	624,8	11,1
	17,5	413,1	11,5
20,0	113,3	12,0	
20,8	0,0	12,1	

Static Pressure: 1 mm H<sub>2</sub>O = 0,04in H<sub>2</sub>O = 9,8 Pa  
Air Flow Rate: 1 m<sup>3</sup>/h = 0,59 cfm

