

| Part Numbers | Specifications | Applications | Features | Options |
|-----------------------------------|--|--------------|---|--|
| 6403501 PUSHER / PULLER | DIAMETER 12" (305 mm) HIGH PROFILE 24V 225W | HVAC Systems | Waterproof, IP68 (LL) Long Life Reversible Airflow High Efficiency | Mounting brackets EMC (Certified) Thermal Protector (ELL) Extreme Long Life |

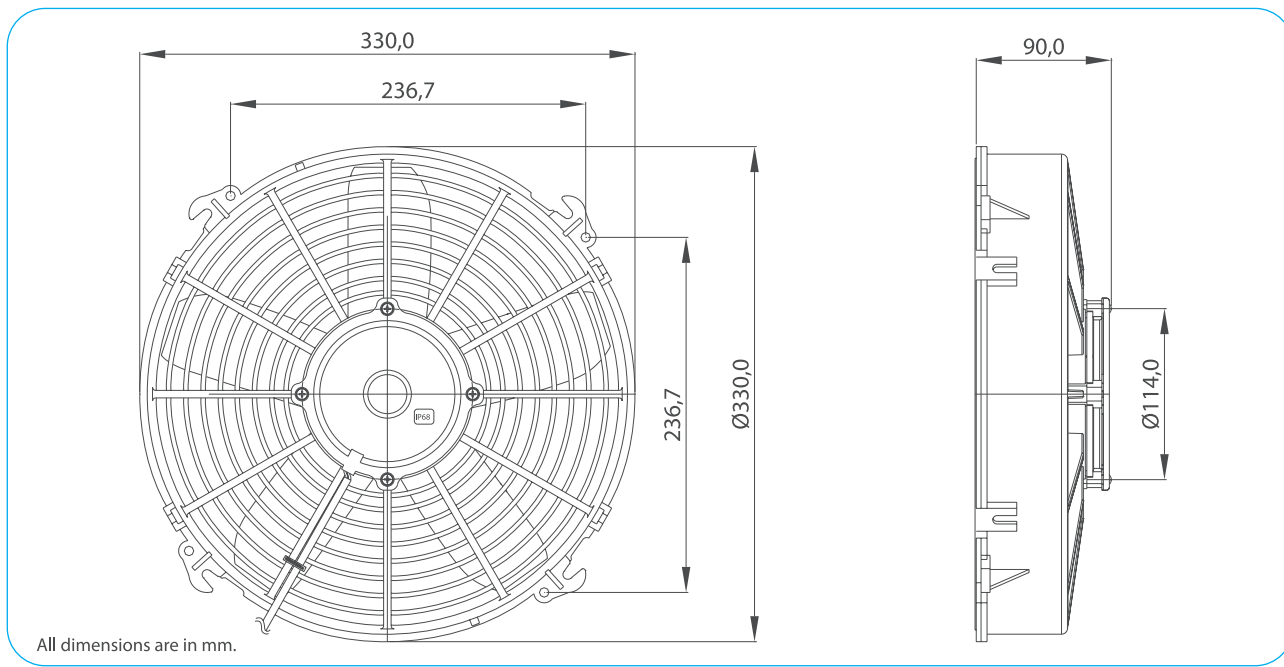

| | | |
|-------------------|--------------------|-------|
| Test Voltage | V | 26,0 |
| Nominal Current | A | 8,6 |
| Nominal Speed | rpm | 3.000 |
| Max. St. Pressure | mmH ₂ O | 41,5 |
| Max. Airflow | m ³ /h | 2.700 |
| Weight | kg | 2,6 |



| TEST VOLTAGE = 26,0 VDC | Static Pressure | Air Flow Rate | Current |
|-------------------------|---------------------|-------------------|---------|
| | mm H ₂ O | m ³ /h | A |
| | 0,0 | 2722,8 | 8,6 |
| | 2,5 | 2638,2 | 8,8 |
| | 5,0 | 2526,1 | 9,0 |
| | 10,0 | 2119,1 | 9,1 |
| | 15,0 | 1565,9 | 9,2 |
| | 20,0 | 1160,4 | 9,7 |
| | 25,0 | 869,6 | 10,1 |
| | 30,0 | 593,3 | 10,4 |
| | 35,0 | 329,3 | 11,1 |
| | 41,4 | 0,0 | 12,6 |

Static Pressure: 1 mm H₂O = 0,04in H₂O = 9,8 Pa
Air Flow Rate: 1 m³/h = 0,59 cfm

