

Part Numbers	Specifications	Applications	Features	Options
6402244 PULLER / STR. BLADE	DIAMETER 12" (305 mm)	HVAC Systems	Waterproof, IP68 (LL) Long Life High Efficiency	Mounting brackets EMC (Certified) Thermal Protector (ELL) Extreme Long Life
6401254 PUSHER / STR. BLADE	LOW PROFILE 24V 160W			

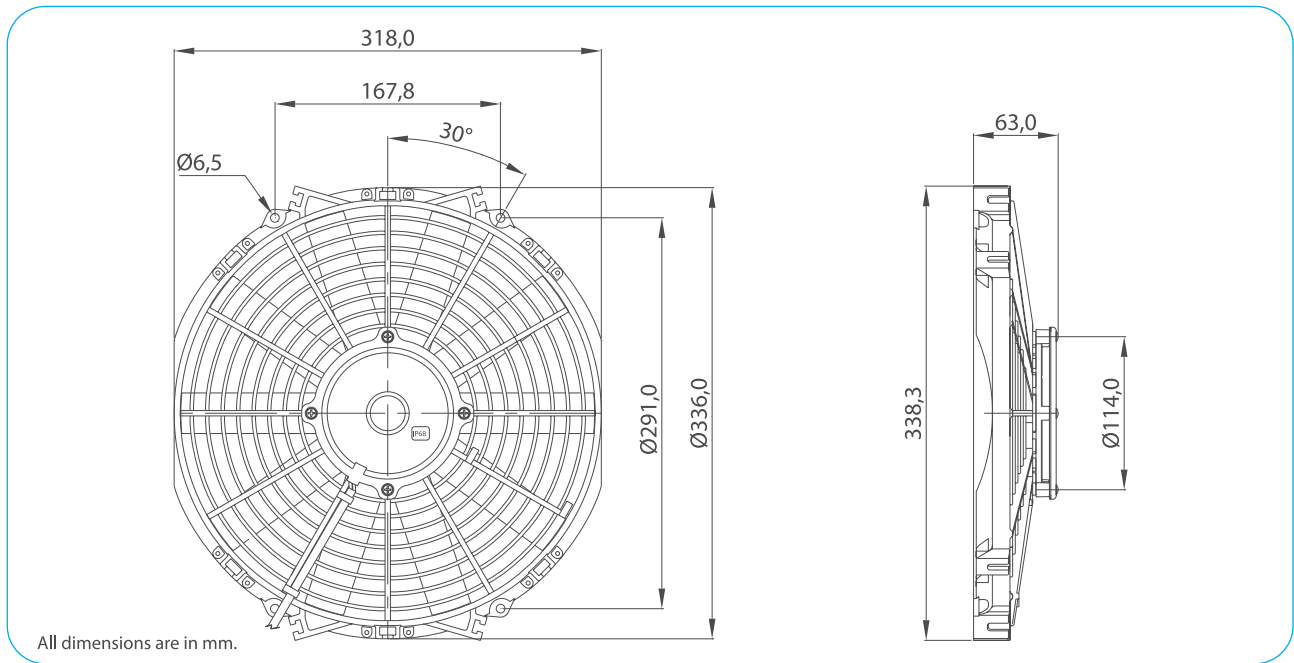

Test Voltage	V	26,0
Nominal Current	A	5,0
Nominal Speed	rpm	3.270
Max. St. Pressure	mmH ₂ O	31,5
Max. Airflow	m ³ /h	2.050
Weight	kg	1,8



TEST VOLTAGE = 26,0 VDC	Static Pressure	Air Flow Rate	Current
	mm H ₂ O	m ³ /h	A
	0,0	2046,4	5,0
	2,5	1960,7	5,3
	5,0	1865,6	5,5
	7,5	1749,0	5,7
	10,0	1607,4	5,8
	15,0	1217,0	5,9
	20,0	779,4	5,8
	25,0	426,9	5,9
30,0	101,8	5,8	
31,5	0,0	5,8	

Static Pressure: 1 mm H₂O = 0,04in H₂O = 9,8 Pa
Air Flow Rate: 1 m³/h = 0,59 cfm

